



### Warning:

- Caution - Risk of Shock. This product must be installed in accordance with the applicable installation code by a person familiar with the construction and operation of the product and the hazards involved.
- Make sure all electrical power is turned off while installing the fixture.
- This luminaire must be adequately grounded for protection against shock hazards and to assure proper operation.
- Disconnect power before servicing.
- Always use correct lamp type and wattages.
- LEDs are ESD (Electro Static Discharge) sensitive devices that can be easily damaged if the proper ESD mitigating steps are not taken.
- LEDs are very sensitive to mechanical damage. Caution must be taken to avoid damage to the LEDs.
- ESD or mechanical damage voids all warranties.

### STEP 1: MOUNTING FIXTURE TO STRUCTURE

- Remove diffuser and reflectors.
- Attach fixture(s) to structure using (4) 1/4-20 screws in the mounting holes provided.

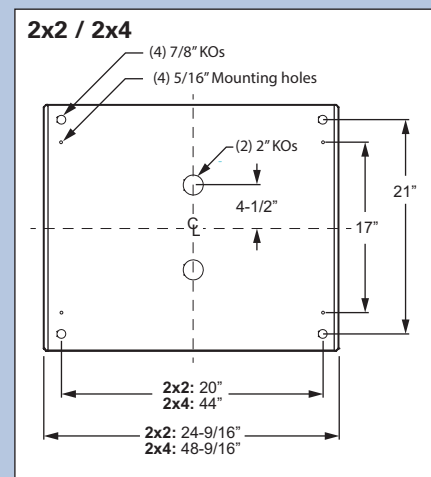
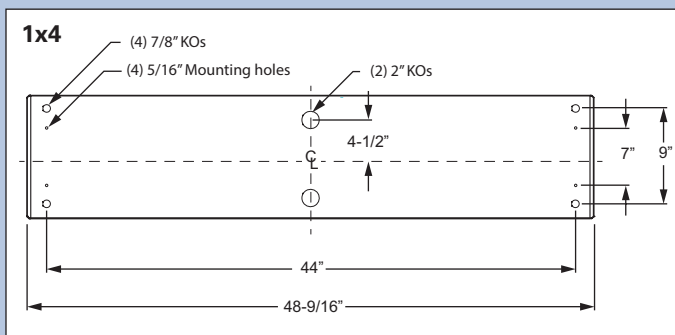

### STEP 2: CONNECT POWER Attach power supply and ground wires using UL listed wire connectors. Ballast disconnect accepts #12 - #16 AWG stranded or solid wire.

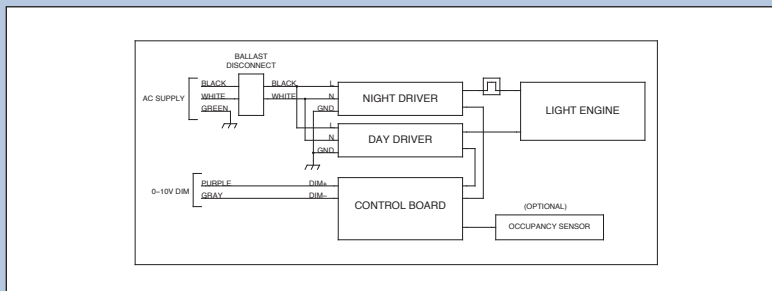

Please consult factory for other driver configurations or emergency driver wiring diagrams.

### STEP 3: INSTALL REFLECTORS & DIFFUSER

- Re-install reflector(s) into housing.
- Install diffuser.
- If dimming is required connect the 0-10v dimming wires as shown in the wiring diagram. If dimming is not required leave the caps on the purple and gray wires.

**Note:** Refer to individual product specification sheets for further information.